



Project 18872EZ: Toy Dump Truck

A sturdy, well-built toy will provide countless hours of fun for a child. Since a toy like this will take a pretty good beating, it's best to use a hardwood. This one is made of poplar, but maple and oak are also good choices.

Toy Dump Truck Materials List

Part	Description	Size	No. Req'd
A	Lower Cab	1-3/4" x 4-1/2" x 3-1/2"	1
B	Upper Cab	1-1/8" x 4-1/2" x 1-7/8"	1
C	Frame		3/4" x 1" x 10" 2
D	Undercarriage	1" x 2" x 8"	1
E	Bumper	1/2" x 1" x 5"	1
F	Axle Support	1" x 1-1/4" x 3-1/2"	3
G	Wheel	1/2" thick x 2-1/2" dia.	10
H	Front Axle	1/4" dia. x 4-3/4"	1
I	Rear Axle	1/4" dia. x 5-3/4"	2
J	Pivot Block	1" x 2" x 1-3/4"	1
K	Bottom	3/4" x 4-1/2" x 6-1/4"	1
L	Edge Strip	3/16" x 3/4" x 4-1/2"	1
M	Side	3/4" x 2-1/2" x 8"	2
N	Front	3/4" x 2-1/2" x 4-1/2"	1
O	Tailgate	3/4" x 3-1/8" x 4-1/2"	1
P	Block Pivot	1/4" dia. x 3-1/2"	1
Q	Tailgate Pivot	3/16" dia. x 1-3/4"	2
R	Dumping Knob	1/2" dia. x 1-5/8"	1
S	Dowels	1/4" dia. x 1-3/8"	3

Toy Dump Truck Complete Schematic

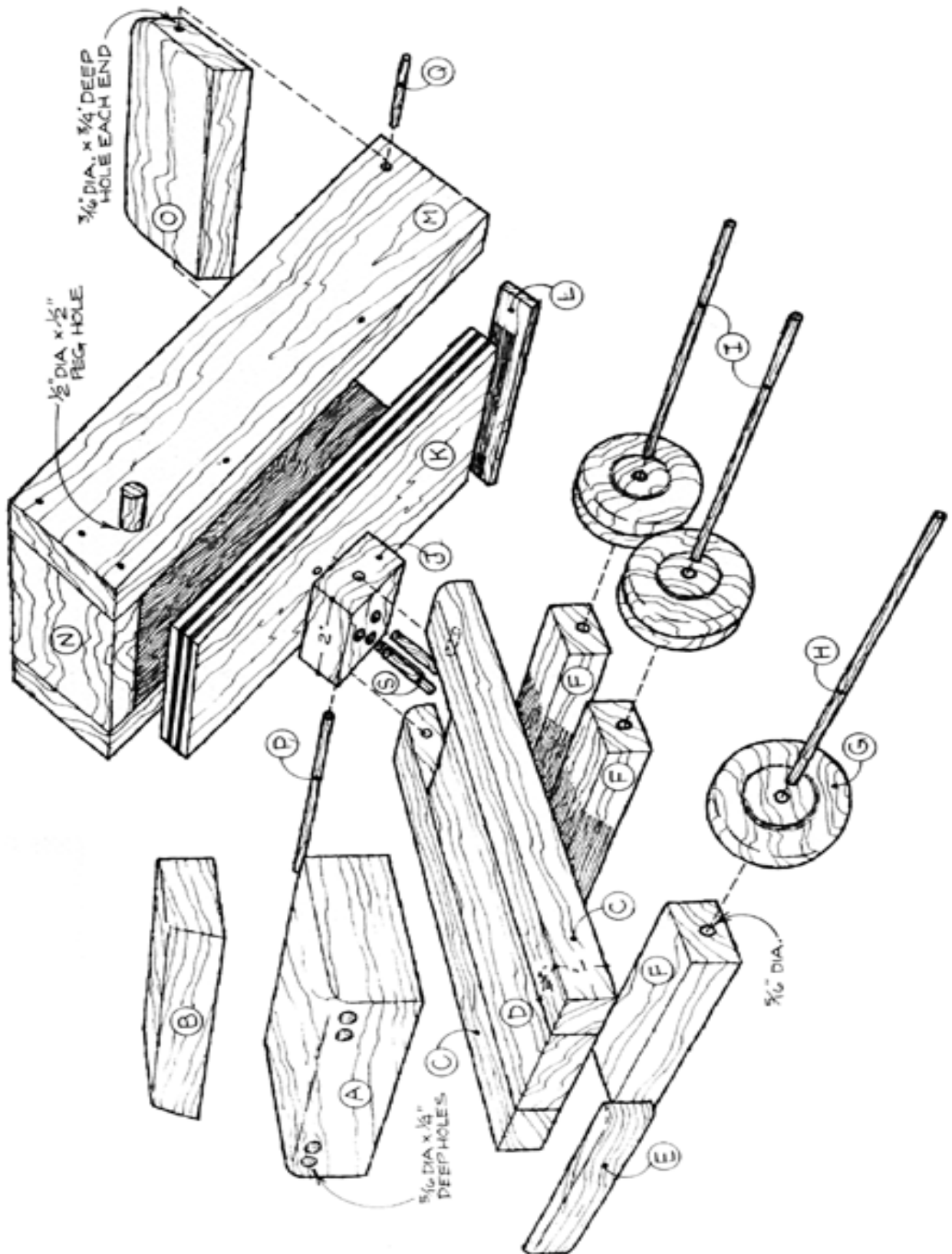

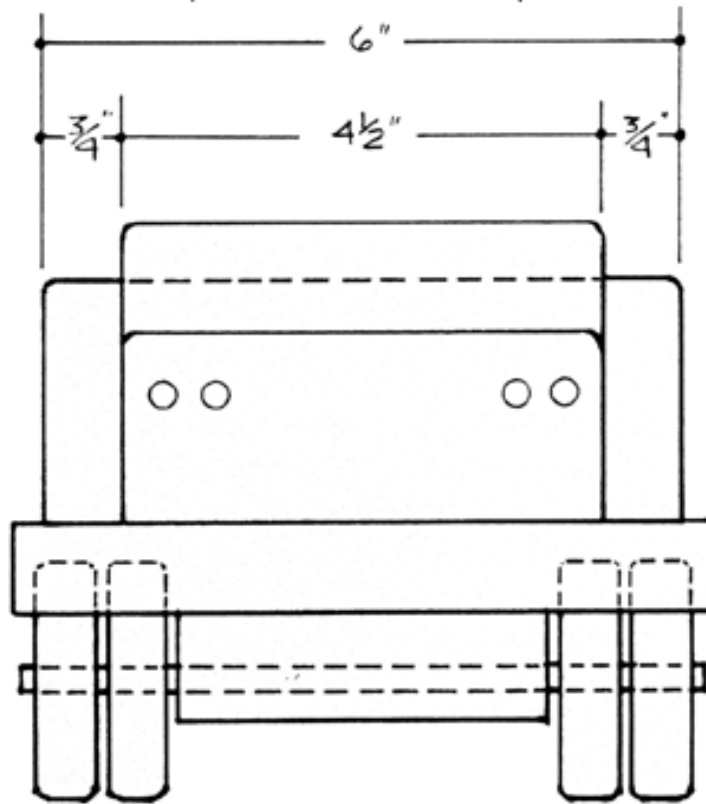
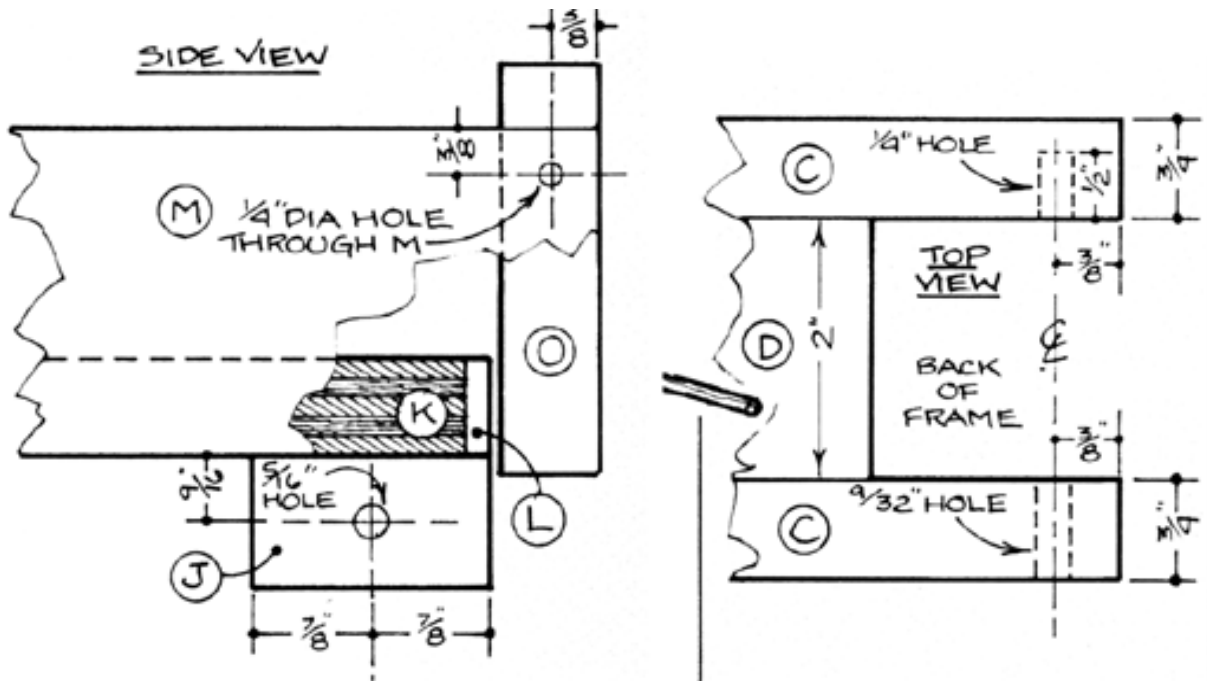

Toy Dump Truck Step-by-Step Instructions

1. Cut the lower cab (part A) to the dimensions shown.
2. Drill $5/16$ " diameter by $1/4$ " deep holes to make four "headlights".
3. Use a file or rasp to round over the "nose".
4. Smooth the nose with sandpaper.
5. Select a piece of $1-1/8$ " thick stock to make the upper cab (B).
6. Cut the stock to a width of $1-7/8$ ".
7. Set the table saw to an angle of about 18 degrees.
8. Make a ripping cut to create the front bevel.
9. Apply glue to the mating surfaces of both parts and clamp in place.
10. Allow to dry overnight.
11. Cut the two frame parts (C) to the dimensions shown in the Materials List.
12. Round over the back end as shown.
13. Lay out the location of the block pivot (P) holes.
14. Use a $1/4$ " drill bit to drill one hole completely through, and the other $1/2$ " deep.
15. Use a small rat-tail file to enlarge the through-hole to a diameter of $9/32$ ".
16. Cut the undercarriage (part D) to size.
17. Glue the undercarriage to the two frame parts (C).
18. Apply glue to the mating surfaces, then clamp securely, being sure the block pivot holes are exactly opposite of each other.
19. Allow to dry overnight.
20. Drill the $5/16$ " diameter axle holes in parts F.
21. Glue the bumper (part E), the axle supports (parts F), and the cab assembly (parts A and B) to parts C and D.
22. Apply clamps and allow to dry.
23. Cut the bottom (K) to size from $3/4$ " hardwood plywood.
24. Glue an edge strip (L) as shown to hide the plywood edge at the back.
25. Cut the pivot block (part J) to the dimensions shown in the Materials List.
26. Drill a $5/16$ " diameter hole through the block at a point $9/16$ " from the top edge and $9/16$ " from the back as shown in the drawing.
27. Cut the two sides (M) to size.
28. Parts M, the two sides, can now be cut to size.
29. Drill a $3/16$ " diameter hole in each side piece for the tailgate pivot (Q), as shown in the detail.

30. Drill a 1/2" diameter x 1/2" deep hole in the left side to take the dumping knob (R).
31. Cut the front (part N) is cut to size.
32. Use glue and finishing nails as shown to join the sides, bottom and front.
33. Locate three dowels (S) to reinforce the joint, then glue the pivot back (J) to the underside of the bottom (K) so that the pivot back it is flush with the back of the edge strip (L) and centered along the width of part K. **NOTE: Make sure that the dowels do not interfere with the block pivot (P).**
34. Set the subassembly consisting of parts K, L, M, and N in position on the subassemblies of parts C and D.
35. Apply glue to the 1/4" diameter x 1/2" deep hole in part C.
36. Drive the block pivot (P) into place.
37. Cut the tailgate (O) to length and width.
38. Drill a 3/16" diameter by 3/4" deep hole in each end.
39. Apply a generous radius to the top corners.
40. Put a small amount of glue into the 3/16" diameter holes in the tailgate, and then drive in the tailgate pivot (Q) to install the tailgate.
41. Lathe-turn the wheels (G) to the dimensions shown.
42. Glue a single wheel on each end of the front axle (H).
43. Glue two wheels on each end of the rear axles (I).
44. Give the entire piece a complete sanding.
45. Remove any sharp edges and round all corners.
46. Clean up any spots where excess glue squeezed out.
47. Leave unfinished.

These plans were originally published in Volume 7, Issue 1 of *The Woodworker's Journal* (Jan./Feb. 1983, pages 35-36).